

Blast Chiller Freezers Crosswise Blast Chiller-Freezer Crosswise 5 1/1 - 15kg (R290) undercounter

ITEM # _____

MODEL # _____

NAME # _____

SIS # _____

AIA # _____

**111362 (ZCBCFA015UE)**

Blast chiller & freezer crosswise 15kg, undercounter, compatible with 6x1/1GN convection oven crosswise - R290

Short Form Specification

Item No.

- Blast chiller/freezer with digital temperature and time display.
- For 5 GN 1/1 or 600x400 mm trays. Up to 4 ice-cream basins of 6.5 l each (360 x 250 x h 80 mm).
- Load capacity: chilling 15 kg; freezing 5 kg.
- Turbo cooling function.
- Thawing function.
- Automatic and manual defrost.
- Blast chilling real remaining time estimation (A.R.T.E.).
- HACCP and Service alarms with data logging. Connectivity ready.
- Single sensor food probe.
- Automatic detection of food probe insertion.
- Main components in 304 AISI stainless steel.
- Internal rounded corners and drain.
- Built-in refrigeration unit.
- Evaporator with antirust protection.
- R290 refrigerant gas.
- Performances guaranteed at ambient temperature of +40°C.
- Cyclopentane insulation (HCFC, CFC and HFC free).
- Suitable for undercounter installation.
- Connectivity ready (optional): enables real time access to the appliance, possibility to share recipes and monitor information, such as status, statistics, HACCP data and consumptions, and receive service alerts

Main Features

- Blast Chilling cycle: 15 kg from 90°C up to 3°C.
- Holding at +3 °C for chilling or -20 °C for freezing, automatically activated at the end of each cycle, to save energy and maintain the target temperature (manual activation is also possible).
- Freezing cycle: 5 kg from 90°C up to -34°C.
- Chilling cycle with automatic preset cycles:
 - Soft Chilling, ideal for delicate food and small portions.
 - Hard Chilling, ideal for solid food and whole pieces.
- Turbo cooling: chiller works continuously at the desired temperature; ideal for continuous production.
- Thawing cycle, ideal for defrosting food in a controlled and safe environment.
- Possibility to modify the cavity temperature in turbo cooling and thawing cycles.
- Remaining time estimation for probe-driven cycles based on artificial intelligence techniques (ARTE) for an easier planning of the activities.
- Single sensor core probe as standard.
- On-board HACCP monitoring capable.
- Performance guaranteed at ambient temperatures of +40°C (Climatic class 5).
- Automatic and manual defrosting.
- Multi-purpose internal structure suitable for gastronomy, bakery trays or ice-cream basins.
- 3-point core probe available on request (optional).

Construction

- IP21 protection index.
- No water connections required.
- Ventilator swinging hinged panel for access to the evaporator for cleaning.
- Waste water can be plumbed into drain, but can also be collected in an optional waste container.
- Built-in refrigeration unit.
- Main components in 304 AISI stainless steel.
- Evaporator with antirust protection.
- Automatic heated door frame.
- Door reversible on site.
- Door stopper to keep the door open in order to avoid the formation of bad smells (kit available to be mounted on site, depending on preferred door hinge).

User Interface & Data Management

- Control unit provides two large displays to read out: time, core temperature, cycle countdown, alarms, service information.
- Connectivity ready for real time access to connected appliances from remote and HACCP monitoring (requires optional accessory).

Sustainability

- High density polyurethane insulation, 60 mm thickness, HCFC free.

Included Accessories

APPROVAL: _____

Blast Chiller Freezers Crosswise Blast Chiller-Freezer Crosswise 5 1/1 - 15kg (R290) undercounter

Front

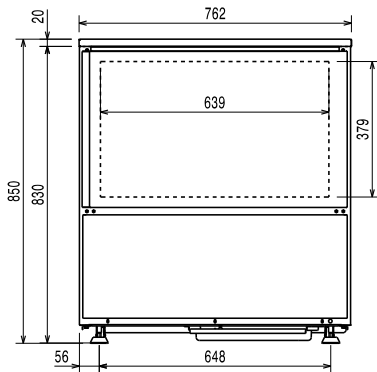

Side

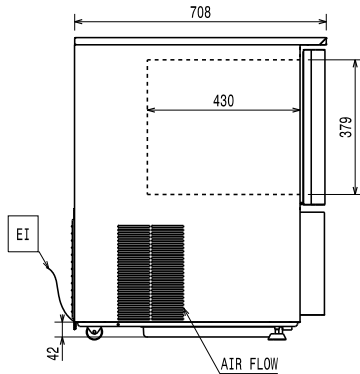

EI = Electrical inlet (power)

Top

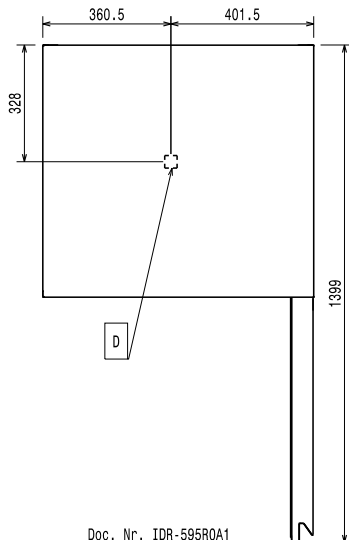

Doc. Nr. IDR-595R0A1

Electric

Circuit breaker required

Supply voltage: 220-240 V/1 ph/50 Hz

Electrical power, max: 1 kW

Installation:

Clearance: 5 cm on sides and back.

Please see and follow detailed installation instructions provided with the unit

Capacity:

Number and type of grids: 5 (GN 1/1; 600x400)

Number and type of basins: 4 (360x250x80h)

Key Information:

External dimensions, Width: 762 mm

External dimensions, Depth: 708 mm

External dimensions, Height: 850 mm

Net weight: 85 kg

Shipping weight: 102 kg

Shipping volume: 0.69 m³

Refrigeration Data

Control type: Electronic

Refrigeration power at evaporation temperature: -10 °C

Operating temperature min.: 16 °C

Operating temperature max.: 40 °C

Product Information (EN17032 – Commission Regulation EU 2015/1095)

Test performed in a test room at 30°C to chill/ freeze (+10°C/-18°C) a full load of 40mm deep trays filled with mashed potatoes evenly distributed up to a height of 35 mm at starting temperature between 65° and 80°C within 120/270min.

Chilling Cycle Time (+65°C to +10°C): 104 min

Full load capacity (chilling): 15 kg

Freezing Cycle Time (+65°C to -18°C): 260 min

Full load capacity (freezing): 5 kg

Sustainability

Refrigerant type: R290

GWP Index: 3

Refrigeration power: 1715 W

Refrigerant weight (unit 1): 130 g

Energy consumption, cycle (chilling): 0.1035 kWh/kg

Energy consumption, cycle (freezing): 0.6353 kWh/kg